

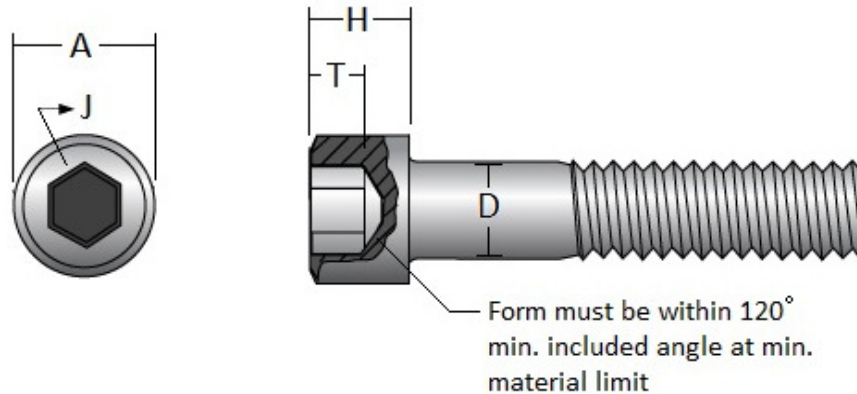

### Socket Cap Screws, Alloy, Black Oxide, Manufactured in the USA

The information below lists the required dimensional, chemical and physical characteristics of the products in this purchase order. If the order received does not meet these requirements, it may result in a supplier corrective action request, which could jeopardize your status as an approved vendor. Unless otherwise specified, all referenced consensus standards must be adhered to in their entirety.



Size	D		A		H		J		T
	Body Diameter		Head Diameter		Head Height		Hex Socket		Key Engagement
	Max.	Min.	Max.	Min.	Max.	Min.	Max.	Min.	Min.
#0	.0600	.0568	.096	.091	.060	.057	0.0510	0.0500	.025
#1	.0730	.0695	.118	.112	.073	.070	0.0635	0.0625	.031
#2	.0860	.0822	.140	.134	.086	.083	0.0791	0.0781	.038
#3	.0990	.0949	.161	.154	.099	.095	0.0791	0.0781	.044
#4	.1120	.1075	.183	.176	.112	.108	0.0952	0.0937	.051
#5	.1250	.1202	.205	.198	.125	.121	0.0952	0.0937	.057
#6	.1380	.1329	.226	.216	.138	.134	0.1111	0.1094	.064
#8	.1640	.1585	.270	.257	.164	.159	0.1426	0.1406	.077
#10	.1900	.1840	.312	.298	.190	.185	0.1587	0.1562	.090
1/4	.2500	.2435	.375	.354	.250	.244	0.1900	0.1875	.120
5/16	.3125	.3053	.469	.446	.312	.306	0.2530	0.2500	.151
3/8	.3750	.3678	.562	.540	.375	.368	0.3160	0.3125	.182
7/16	.4375	.4294	.656	.631	.438	.430	0.3790	0.3750	.213
1/2	.5000	.4919	.750	.725	.500	.492	0.3790	0.3750	.245
5/8	.6250	.6163	.938	.914	.625	.616	0.5050	0.5000	.307
3/4	.7500	.7406	1.125	1.094	.750	.740	0.6310	0.6250	.370
7/8	.8750	.8647	1.312	1.291	.875	.864	0.7570	0.7500	.432
1	1.000	.9886	1.500	1.476	1.000	.988	0.7570	0.7500	.495
1 1/4	1.250	1.2336	1.875	1.852	1.250	1.236	0.8850	0.8750	.620
1 1/2	1.500	1.4818	2.250	2.224	1.500	1.485	1.0200	1.0000	.745

Page 2 of 2	<b>Holo-Krome Product Standard</b>	REV-09
Date: February 1, 2017		HK.SHCS.ALLOY.BO



### Specification Requirements:

- Dimensions: ASME B18.3
- Material & Mechanical Properties: ASTM A574
- Thread Requirements: ASME B1.1, Class 3A UNRC and UNRF (0.060" to 1" inclusive)  
Class 2A UNRC and UNRF (Over 1")
- Product Marking: Manufacturer's ID
- Finish: Black Oxide (Thermal or Chemical)
- Material Test Reports: The MTR must have documented lot traceability, dimensional results, full chemical test results and full mechanical test results to the specification(s) above. In addition, the MTR shall be in full compliance with Fastenal's MTR Requirements.
- Quality Assurance Provisions: Category 3 of ASME B18.18