

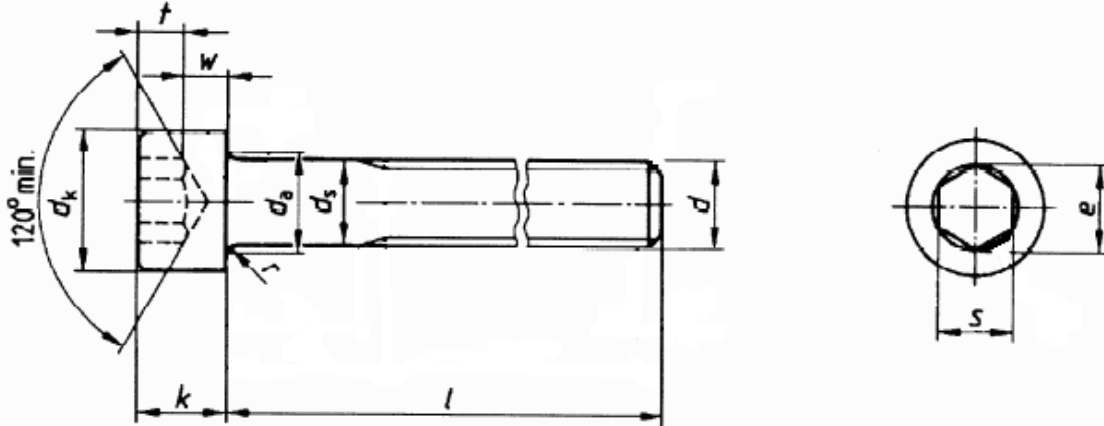

Socket Head Cap Screws, Metric, A2-70 Stainless Steel, Manufactured in the USA

The information below lists the required dimensional, chemical and physical characteristics of the products in this purchase order. If the order received does not meet these requirements, it may result in a supplier corrective action request, which could jeopardize your status as an approved vendor. Unless otherwise specified, all referenced consensus standards must be adhered to in their entirety.



Diameter	dk		da	ds		k		e	s		r	t	w
	Max.	Min.	Max.	Max.	Min.	Max.	Min.	Min.	Max.	Min.	Min.	Min.	Min.
M3	5.50	5.32	3.60	3.00	2.86	3.00	2.86	2.87	2.58	2.52	0.1	1.3	1.15
M4	7.00	6.78	4.70	4.00	3.82	4.00	3.82	3.44	3.08	3.02	0.2	2.0	1.40
M5	8.50	8.28	5.70	5.00	4.82	5.00	4.82	4.58	4.095	4.02	0.2	2.5	1.90
M6	10.00	9.78	6.80	6.00	5.82	6.00	5.70	5.72	5.14	5.02	0.25	3.0	2.30

Specification Requirements:

- Dimensions: ISO 4762
- Threads: 6g
- Material & Mechanical: ISO 3506-1. A2-70, Stainless Steel, Cold Worked.
- Marking: Sizes M5 and larger;
 - 1) Manufacturer ID
 - 2) A2-70
- Finish: Clean or descaled
- Material Test Reports: The MTR must have documented lot traceability, including full chemical and mechanical figures, to the specification(s) above.