

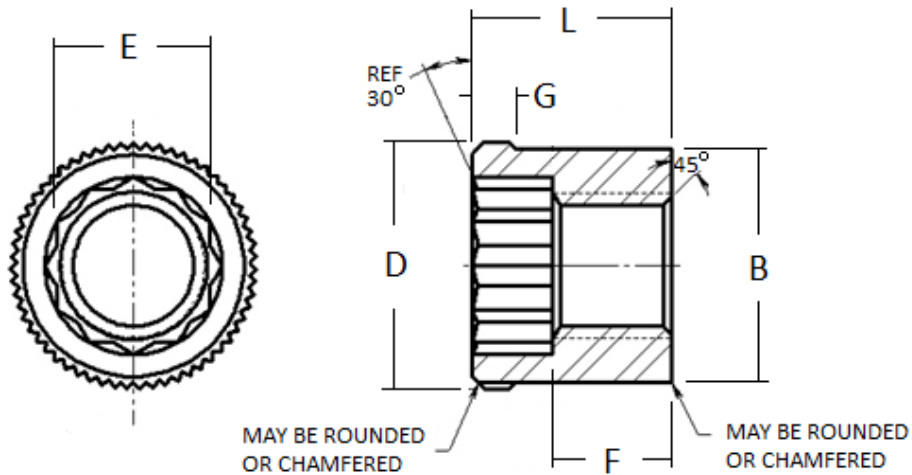

Allen Nut, Black Oxide

This product standard contains the required dimensional, mechanical, performance, and chemical characteristics of the products shown in this purchase order (as applicable to the product). Unless specified below, current revisions of national or international standards shall be applicable as of the date of Fastenal's purchase order and must be adhered to in their entirety. If the order received does not meet these requirements, corrective action may be issued which could jeopardize your status as an approved supplier to Fastenal.



Nominal Nut Size	B		L		D		E	F	G
	Body Diameter		OAL		Knurl Diameter		Socket WAF	Thread Length	Knurl Length
	Max.	Min.	Max.	Min.	Max.	Min.	Nom.	Min.	Min.
#4	0.187	0.183	0.179	0.172	0.209	0.205	1/8	0.080	0.046
#5	0.187	0.183	0.205	0.198	0.209	0.205	1/8	0.095	0.056
#6	0.257	0.253	0.230	0.223	0.278	0.274	5/32	0.100	0.071
#8	0.280	0.275	0.273	0.226	0.307	0.302	3/16	0.125	0.084
#10	0.307	0.302	0.319	0.309	0.366	0.331	3/16	0.170	0.096
1/4	0.403	0.398	0.419	0.409	0.430	0.425	1/4	0.225	0.136
5/16	0.498	0.493	0.522	0.512	0.526	0.521	5/16	0.285	0.165
3/8	0.590	0.585	0.621	0.606	0.620	0.615	3/8	0.325	0.195
7/16	0.710	0.705	0.733	0.718	0.743	0.738	7/16	0.360	0.235
1/2	0.800	0.795	0.836	0.821	0.841	0.836	1/2	0.445	0.265
5/8	0.986	0.980	1.010	0.995	1.040	1.034	5/8	0.500	0.325
3/4	1.158	1.152	1.185	1.170	1.215	1.209	3/4	0.600	0.385
7/8	1.361	1.355	1.358	1.343	1.430	1.424	7/8	0.700	0.445
1	1.533	1.527	1.532	1.517	1.620	1.612	1	0.810	0.495

RECORD OF REVISION CHANGES TO THIS DOCUMENT ARE LOCATED ON THE LAST PAGE



Specification Requirements:

- Dimensions: See Table Above
- Material: Alloy Steel, Oil Quenched [33-39 HRC]
- Mechanical: Shall meet ASTM A194/A194M Grade 2H, Heavy Hex Nut Proof Loads
- Threads: Per ASME B1.1, UNC & UNF, Class 2B
- Marking: Manufacturer's I.D.
- Finish: Black Oxide (Thermal or Chemical)

Revision Level Changes to this Document

Document Name	Revision Level	Revision Date	Rationale for Revision
HK.ALLNUT.BO	03	6/5/2018	Revised mechanical specification callout.

The rationale above may not include all of the changes within each revision. A complete review of the Fastenal Product Standard is required.