

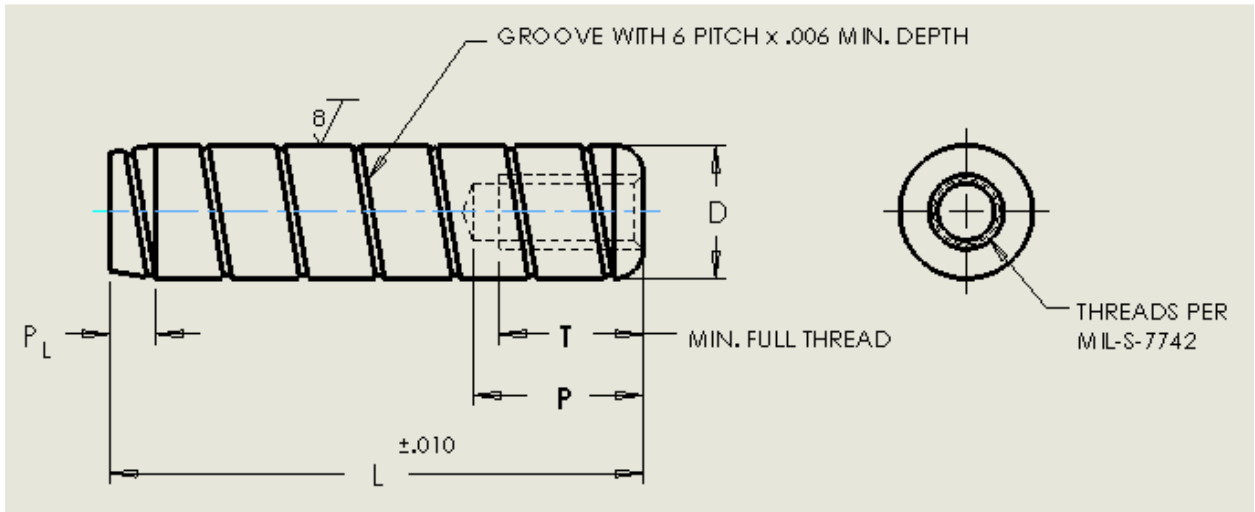

### Pins, Pull Dowel, Spiral, Bright Finish

The information below lists the required dimensional, chemical and physical characteristics of the products in this purchase order. If the order received does not meet these requirements, it may result in a supplier corrective action request, which could jeopardize your status as an approved vendor. Unless otherwise specified, all referenced consensus standards must be adhered to in their entirety.



Nominal Size	Thread Size	D		P <sub>L</sub>	P	T
		Max.	Min.	Min.	Max.	Min.
5/16	#10-32 UNF-2B	0.3128	0.3126	0.060	0.625	0.344
3/8	#10-32 UNF-2B	0.3753	0.3751	0.070	0.625	0.344
1/2	1/4-20 UNC-2B	0.5003	0.5001	0.080	0.750	0.375
5/8	1/4-20 UNC-2B	0.6253	0.6251	0.080	0.750	0.375
3/4	5/16-18 UNC-2B	0.7503	0.7501	0.110	0.875	0.375
1	3/8-16 UNC-2B	1.0003	1.0001	0.110	0.875	0.375

### Specification Requirements:

- Dimensions: See dimensions above.
- Material & Mechanical Properties: Hardened, ground, machined carbon or alloy steel. Sulfur and Phosphorus content must not be in excess of 0.05 and 0.04 percent, respectively. Case hardness minimum 60 HRC, Case depth to be .020" minimum. Core hardness of 50-58 HRC.
- Finish: Bright on ground surfaces